

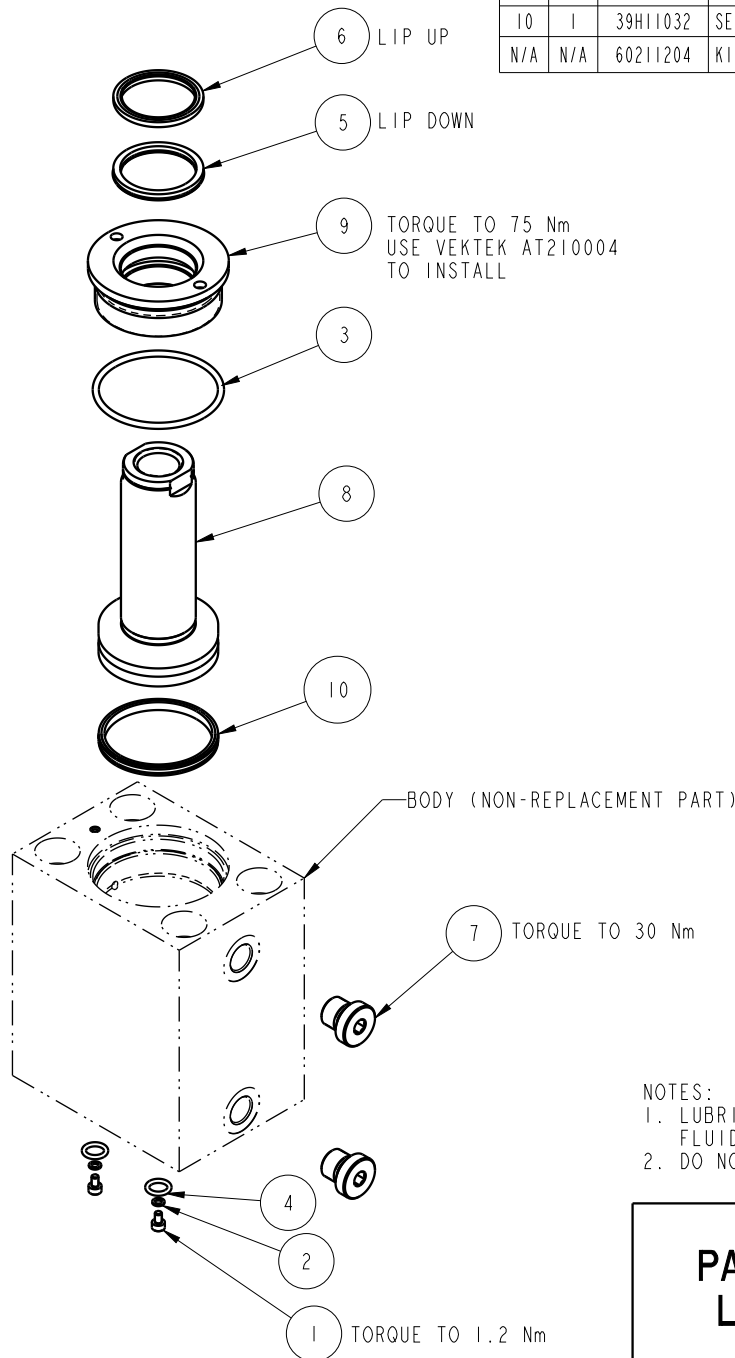

NO	QTY	PART NO	DESCRIPTION	STD SEAL KIT
1	2	21500018	SCREW, CAP, SOCH, M3 X 5, ALY	
2	2	21500200	WASHER	
3	1	39001028	O-RING, (-136)	X
4	2	39050042	O-RING, (-011)	X
5	1	39052037	SEAL, LL, (1-1/4 X 1/8 X 1/8 X 1-1/2)	X
6	1	39053057	WIPER,PRESS-IN, (1-1/4)	X
7	2	43068006	PLUG, PORT, HOLLOW HEX, G1/4	
8	1	48211019	PISTON, CYL, BB, COMBO, 70,9 KN, 50	
9	1	48211024	GLAND, CYL, BB, COMBO, 70,9 KN	
10	1	39H11032	SEAL, T, (1 13/16 X 5/32 X 2)	X
N/A	N/A	60211204	KIT, SEAL, CYL, BB, COMBO, DA, 70.9 KN	NOTED



- NOTES:
- LUBRICATE ALL SEALS WITH CLEAN HYDRAULIC FLUID PRIOR TO INSTALLATION.
 - DO NOT USE SILICONE TYPE LUBRICANTS.

PARTS LIST	 VEKTEK, INC. 1334 E. SIXTH AVE. P.O. BOX 625 EMPORIA, KS. 66801 U.S.A.	
	ASSEMBLIES AFFECTED	PARTS LIST, CYL, BB, COMBO, DA, 70.9 KN, 50
	42112109	
	L2112109	
SIZE A	MPLV4209	REV F

F	4246	RELEASE	MJUST	8/4/20
REV	IN ACCORDANCE WITH ECN	EFFECTIVE DATE	REVISED BY	DATE
DRW BY: K. ROEMER	DRAWING STATUS: Released			
DATE: 11/09/11	PRODUCTION APPROVED FOR RELEASED STATUS ONLY			

FORM FEG035_PL_ASIZE, REV. B

SHEET 1 OF 1